

## Features

- Fast Response to Input Signal changes results in faster loop control and savings in process materials.
- Integrated Volume Booster Output meets input requirements of final control elements requiring a higher capacity output signal and/or increased output pressure.
- Six Input Signal Ranges meet most process and machine requirements.
- Negative Bias Option allows zero pressure based operation.
- Five Booster Ratios meet industrial equipment requirements for higher output pressure ranges.
- Temperature Compensation provides stable operation under environmental changes.
- Vibration Resistance maintains set points under adverse vibration conditions.
- Various Mounting Configurations allow installation flexibility for most applications.
- NEMA 3R or optional NEMA 4X Enclosure for outdoor and indoor installations.
- Conduit Port for convenient wiring.

## Operating Principles

The T5220 Transducer is an electro-pneumatic device that converts a DC current or voltage input signal to a proportional pneumatic output. This device is made up of three sections, the Signal Conversion Section, the Pneumatic Section and Booster Section.

The Signal Conversion Section (PC Board) accepts a DC current or voltage. This signal is applied to a coil which creates a magnetic force that moves a Flexure Arm.

The Pneumatic Section operates as a force balance system. A Sapphire Ball floats inside a Nozzle and controls the output pressure by exhausting air supplied through an Orifice. This Sapphire Ball acts as a piston exerting a force which is balanced against the force transferred to the Flexure Arm by the Coil.

The Booster Section amplifies the output pressure of the transducer. At set point, the force due to transducer output pressure acting on the top of the Upper Diaphragm is balanced by the force due to booster output pressure acting on the underside of the Lower Diaphragm. Any imbalance results in actuation of the appropriate supply valve or exhaust valve to correct the output pressure.

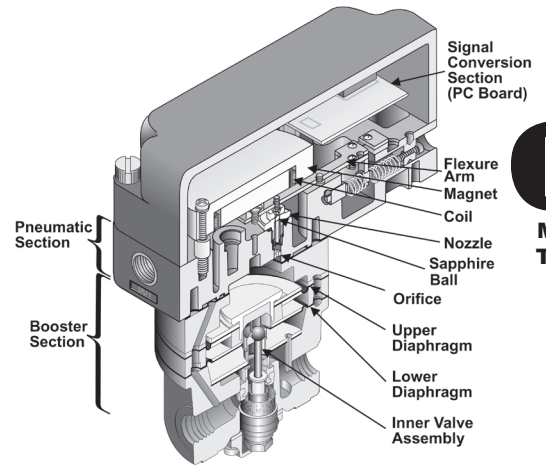

# B

Model  
T5220

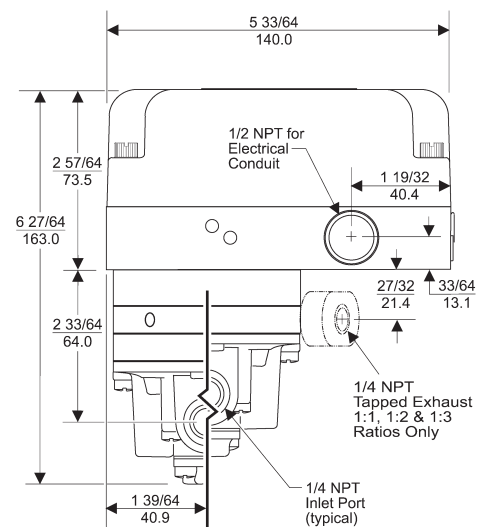
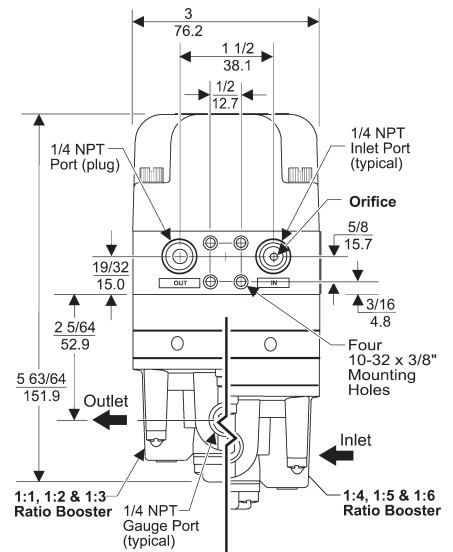

# Model T5220 Electro-Pneumatic I/P, E/P Transducer

**B**

**Model T5220**

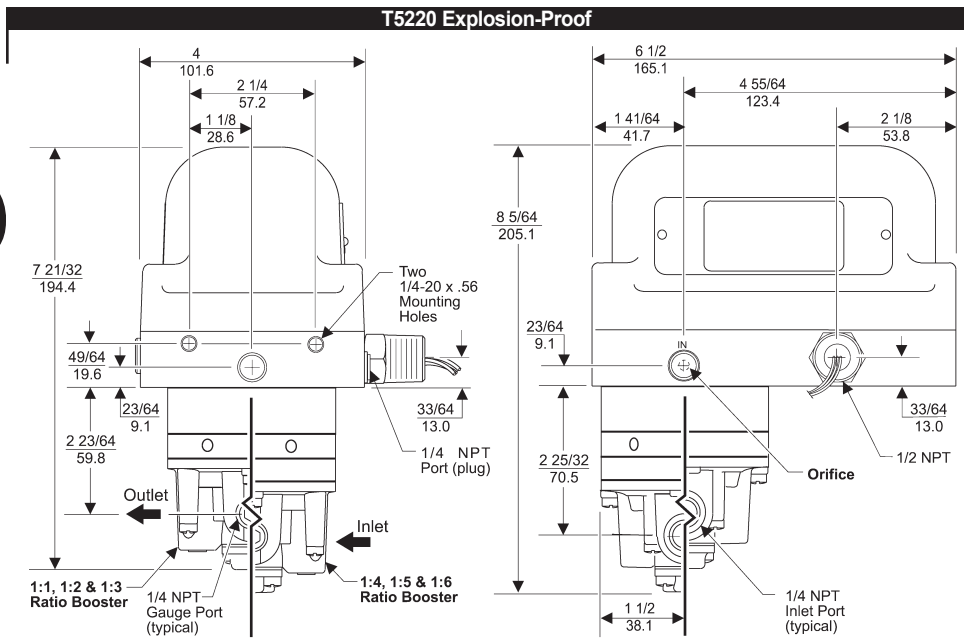

## Hazardous Area Specifications

	Explosion-Proof	Intrinsically Safe										
Factory Mutual (FM) Approvals	<b>TFXPD5220</b> Class I, Division 1, Groups B, C and D; Class II, Division 1, Groups E, F, and G; Maximum Ambient 65° C.	<b>TFI5220</b> Class I, Division 1, Groups A, B, C, and D; Class II, Division 1, Groups E, F, and G; Class III, Division 1, Fibers; NEMA 3R Enclosure. ( <b>Upright Position ONLY</b> )										
	<b>TFXPDI5220</b> Class I, Division 1, Groups A, B, C, and D; Class II, Division 1, Groups E, F, and G; Class III, Division 1, Fibers; NEMA 3R Enclosure. ( <b>Upright Position ONLY</b> )	<table border="1"> <thead> <tr> <th colspan="2">Entity Parameters</th> </tr> </thead> <tbody> <tr> <td>Voc<sup>1</sup> = 40 VDC</td> <td>Ca<sup>3</sup> = 0 μF</td> </tr> <tr> <td>Isc<sup>2</sup> = 125 mA</td> <td>La<sup>4</sup> = 0 mH</td> </tr> <tr> <td><sup>1</sup>Voc = Open Circuit Voltage</td> <td><sup>3</sup>Ca = External Capacitance</td> </tr> <tr> <td><sup>2</sup>Isc = Short Circuit Voltage</td> <td><sup>4</sup>La = External Inductance</td> </tr> </tbody> </table>	Entity Parameters		Voc <sup>1</sup> = 40 VDC	Ca <sup>3</sup> = 0 μF	Isc <sup>2</sup> = 125 mA	La <sup>4</sup> = 0 mH	<sup>1</sup> Voc = Open Circuit Voltage	<sup>3</sup> Ca = External Capacitance	<sup>2</sup> Isc = Short Circuit Voltage	<sup>4</sup> La = External Inductance
	Entity Parameters											
Voc <sup>1</sup> = 40 VDC	Ca <sup>3</sup> = 0 μF											
Isc <sup>2</sup> = 125 mA	La <sup>4</sup> = 0 mH											
<sup>1</sup> Voc = Open Circuit Voltage	<sup>3</sup> Ca = External Capacitance											
<sup>2</sup> Isc = Short Circuit Voltage	<sup>4</sup> La = External Inductance											
<b>TFN5220</b> NEMA 4X Enclosure.												

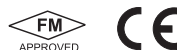

## Mounting Kits

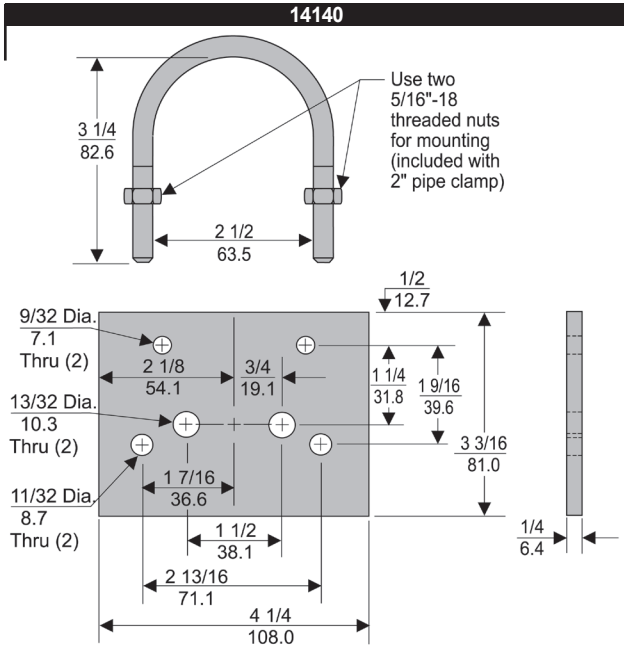

**2" Pipe Mounting Configuration**  
shown with Model TXPD5220

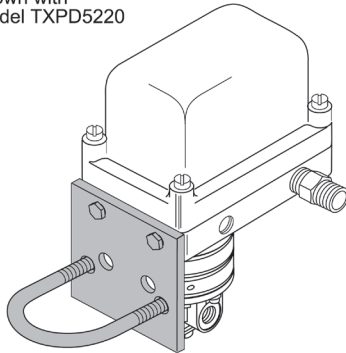

**Mounting Kit 14140**  
Includes the following:  
Mounting Plate • 2" Pipe Clamp  
Support Bar • Two 1/4" Lockwashers  
Two 1/4-20 x 5/8" Bolts • Two 3/8" Lockwashers  
Two 3/8-16 Nuts • Two 3/8-16 x 1 1/2" Caps

## Model T5220 Transducer Kits & Accessories

- Mounting Bracket Kits ..... 14140 (sold separately)  
15268 (sold separately)  
14596 (sold separately)

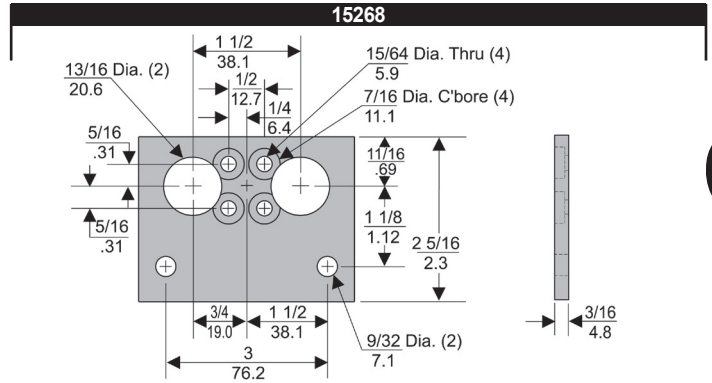

**Panel Mounting Configuration**  
shown with Model T5220

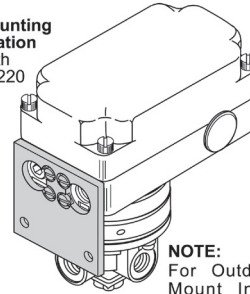

**NOTE:**  
For Outdoor Use,  
Mount In Upright  
Position. (cover up)

**Mounting Kit 15268**  
Includes the following:  
Mounting Bracket • Four 10-32 x 7/16" Screws

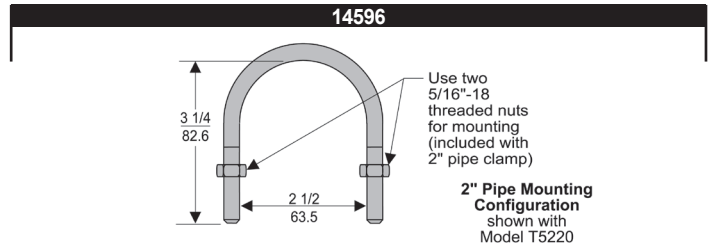

**2" Pipe Mounting Configuration**  
shown with Model T5220

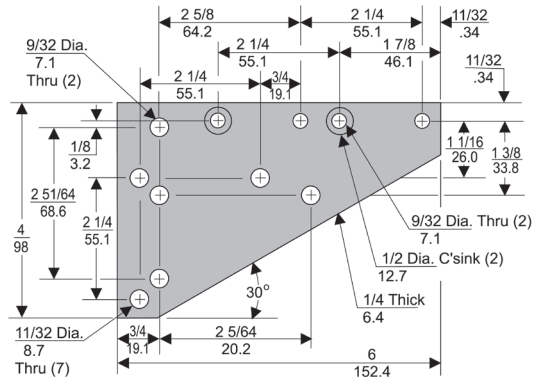

**NOTE:**  
If Not Mounted In An Upright Position, Zero & Span Adjustments Must Be Re-Calibrated For Proper Output Range.

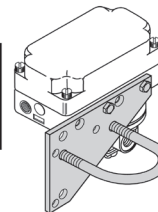

**NOTE:**  
For Outdoor Use,  
Mount In Upright  
Position. (Cover up)

**Mounting Kit 14596**  
Includes the following:  
Mounting Bracket • Two Lockwashers  
2" Pipe Clamp • Two 1/4-20 x 5/8" Bolts  
Two 1/4-20 x 1/2" Screws

# Model T5220 Electro-Pneumatic I/P, E/P Transducer

## Specifications

### Supply Pressure<sup>1</sup>

20 + 2 psig, [1.5 + 0.15 BAR], (150 + 15 kPa)

### Output Capacity (SCFM)

15 (25.5 m<sup>3</sup>/HR) Max. @ 20 psig, [1.5 BAR], (150 kPa) supply.  
45 (76.5 m<sup>3</sup>/HR) @ 100 psig, [7.0 BAR], (700 kPa) (with separate supply.)

### Exhaust Capacity (SCFM)

7 (11.9 m<sup>3</sup>/HR) downstream pressure @ 5 psig, [.35 BAR], (35 kPa) above 3 psig, [0.2 BAR], (20 kPa) set point.  
14 (23.8 m<sup>3</sup>/HR) downstream pressure @ 5 psig, [.35 BAR], (35 kPa) above 15 psig, [1.0 BAR], (100 kPa) set point.

### Air Consumption (SCFM)

0.28 (0.48 m<sup>3</sup>/HR) Max. (dead end) @ 20 psig, [1.5 BAR], (150 kPa) supply

### Output Range (1:1 Ratio)

3-15 psig, [0.2-1.0 BAR], (20-100 kPa)

### Supply Pressure Effect

+ 0.3% of Span for a 1 psig, [0.07 BAR], (7 kPa) supply change between 18-22 psig, [1.2-14.5 BAR], (120-145 kPa).

### Shock & Vibration Effect

Negligible up to 2 g's between 5 Hz and 200 Hz

### Terminal Based Linearity

+ 0.50% Full Scale (T5220 only), within 0.6% Output Span (T5222-T5226)

### Independent Linearity

within 0.25% Full Scale (T5220 only), within 0.3% Output Span (T5222-T5226)

### Hysteresis & Repeatability

within 0.1% Full Scale (T5220 only), within 0.1% Times Ratio of Output Span (T5222-T5226)

Impedance / Input Signal	Range	OHMS (nominal)
	4-20 mA	120
	10-50 mA	50
	1-5 VDC	375
	0-6 VDC	375 <sup>2</sup>
	0-12 VDC	2550 <sup>2</sup>
	1-9 VDC	2550

<sup>2</sup> Not approved for Intrinsically Safe Ratings

### Ambient Temperature

-40° F to +150° F, (-40° C to +65.5° C)

### Temperature Coefficient

Less than 1% of Span / 50° F (10° C)

### Materials of Construction

Body and Housing . . . . . Aluminum  
Ball and Orifice . . . . . Sapphire, Brass  
Nozzle . . . . . Stainless Steel

**Table 1. Pressure Ranges**

Ratio	Standard Output			Negative Bias Output (B) Option		
	psig	[BAR]	(kPa)	psig	[BAR]	(kPa)
1:1 <sup>1</sup>	3-15	[0.2-1.0]	(20-100)	0-12	[0-0.8]	(0-80)
1:2 <sup>2</sup>	6-30	[0.3-2.0]	(30-200)	0-24	[0-1.5]	(0-150)
1:3 <sup>2</sup>	9-45	[0.6-3.0]	(60-300)	0-36	[0-2.5]	(0-250)
1:4 <sup>2</sup>	12-60	[0.9-4.0]	(90-400)	0-48	[0-3.0]	(0-300)
1:5 <sup>2</sup>	15-75	[1.0-5.0]	(100-500)	0-60	[0-4.0]	(0-400)
1:6 <sup>2</sup>	18-90	[1.2-6.0]	(120-600)	0-72	[0-5.0]	(0-500)

<sup>1</sup> Standard unit is configured for common supply to transducer and booster.

<sup>2</sup> Units require 20 psig, [1.5 BAR], (150 kPa) for transducer and a separate supply for booster. A common supply of up to 110 psig, [7.7 BAR], (770 kPa) can be used provided the prefix Z147 is added to the original order, and the supply pressure is noted.

## Catalog Information

**Catalog Number** T     522  -

**Underwriting Group**  
Factory Mutual . . . . . F

### Approval Class

Explosion-Proof<sup>1</sup> . . . . . XPD  
NEMA 4X/IP65<sup>1</sup> . . . . . N  
None (leave blank) . . . . . I

Intrinsically Safe<sup>2</sup> . . . . . I  
None (leave blank) . . . . .

### Options

Negative Bias- 3 psig, [0.2 BAR], (20 kPa) . . . . . B  
High Option<sup>3</sup> . . . . . HI

### Booster Ratio<sup>4</sup>

1:1 (standard) . . . . . 0  
1:2 . . . . . 2  
1:3 . . . . . 3  
1:4 . . . . . 4  
1:5 . . . . . 5  
1:6 . . . . . 6

### Input

4-20 mA . . . . . 4  
10-50 mA<sup>5</sup> . . . . . 5  
1-5 VDC . . . . . 6  
0-6 VDC<sup>6</sup> . . . . . 8  
0-12 VDC<sup>6</sup> . . . . . 9  
1-9 VDC . . . . . 9

### Output Pressure Units

psig . . . . . 0  
[BAR] . . . . . 1  
(kPa) . . . . . 2

### Options

Tapped Exhaust - 1:1, 1:2, or 1:3 Ratios Only . . . . . E

<sup>1</sup> Factory Mutual Approval Only.

<sup>2</sup> Intrinsically Safe Units cannot be set for Reverse Acting Mode in field.

<sup>3</sup> If high flow (SCFM) is required for the standard 1:1 ratio, select HI Option. Separate supply is required.

<sup>4</sup> Refer to Table 1. for Pressure Ranges

<sup>5</sup> Units shipped calibrated 4-20 mA; 10-50 mA units must be calibrated in field.

<sup>6</sup> Not approved for intrinsically safe ratings.

## Installation

For Installation Instructions, refer to the *Fairchild T5220 Series Electro-Pneumatic Transducer Installation, Operation & Maintenance Instructions*, IS-500T5220.